

3-INPUT 1-OUTPUT VIDEO SWITCH

■ GENERAL DESCRIPTION

The NJM2535 is a video switch for VCR, TV and others.
It contains three cramp-type inputs and one buffer-type output.

■ PACKAGE OUTLINE

■ FEATURES

- Operating Voltage (+4.5V ~ +13V)
- Low Operating Current (4.6mA MAX)
- Crosstalk (-70dB)
- 3-Input, 1-Output
- Bipolar Technology
- Package Outline DIP8, DMP8, SIP8, SSOP8

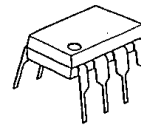

NJM2535D

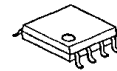

NJM2535M

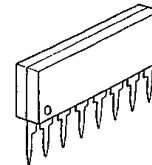

NJM2535L



NJM2535V

■ PIN CONFIGURATION

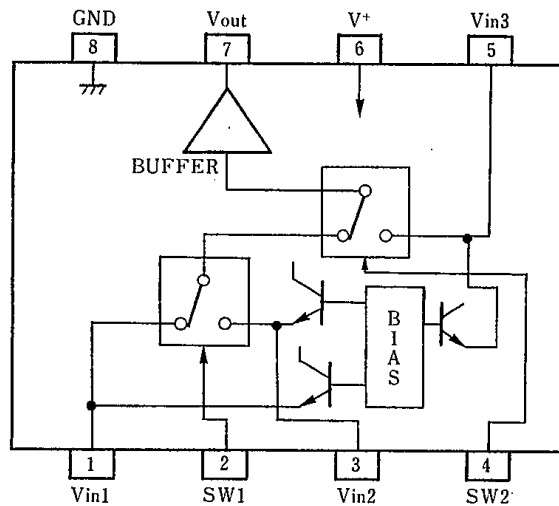

PIN FUNCTION

- 1 : Vin1
- 2 : SW1
- 3 : Vin2
- 4 : SW2
- 5 : Vin3
- 6 : V+
- 7 : V_{OUT}
- 8 : GND

NJM2535D
NJM2535M
NJM2535V

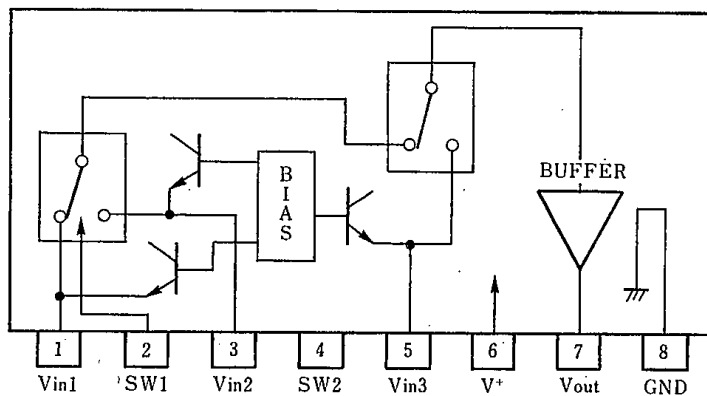

PIN FUNCTION

- 1 : Vin1
- 2 : SW1
- 3 : Vin2
- 4 : SW2
- 5 : Vin3
- 6 : V+
- 7 : V_{OUT}
- 8 : GND

NJM2535L

■ ABSOLUTE MAXIMUM RATINGS

(Ta=25°C)

PARAMETER	SYMBOL	RATINGS	UNIT
Supply Voltage	V ⁺	+15	V
Power Dissipation	P _D	(DIP-8) 500 (DMP-8) 300 (SIP-8) 800 (SSOP-8) 250	mW
Operating Temperature Range	T _{opr}	-20~+75	°C
Storage Temperature Range	T _{stg}	-40~+125	°C

■ ELECTRICAL CHARACTERISTICS

(V⁺=5V, Ta=25°C)

PARAMETER	SYMBOL	TEST CONDITIONS	MIN.	TYP.	MAX.	UNIT
Supply Voltage	V ⁺		+4.5	—	+13.0	V
Supply Current	I _{CC}		—	3.6	4.6	mA
Frequency Characteristics	G _f	V _{IN} =2V _{pp} , V _O =10MHz/100kHz	-1.0	0	+1.0	dB
Voltage Gain	G _v	V _{IN} =2V _{pp} , 100kHz	-0.5	0	+0.5	dB
Differential Gain	DG	V _{IN} =2V _{pp} , Standard staircase signal, APL=50%	—	0	3.0	%
Differential Phase	DP	V _{IN} =2V _{pp} , Standard staircase signal, APL=50%	—	0	3.0	deg
Output Offset Voltage	V _{off}		-30	0	+30	mV
Crosstalk	CT	V _{IN} =2V _{pp} , 4.3MHz	—	-70	-60	dB
Switching Voltage	V _{CH}		2.4	—	—	V
	V _{CL}		—	—	0.8	V
Input Impedance	R _I		—	30	—	kΩ
Output Impedance	R _O		—	25	—	Ω
Input Bias Voltage	V _{IN}		—	2.5	—	V

■ INPUT CONTROL SIGNAL-OUTPUT SIGNAL

SW1	SW2	OUTPUT SIGNAL
L	L	V _{IN1}
H	L	V _{IN2}
L/H	H	V _{IN3}

■ TEST CIRCUIT

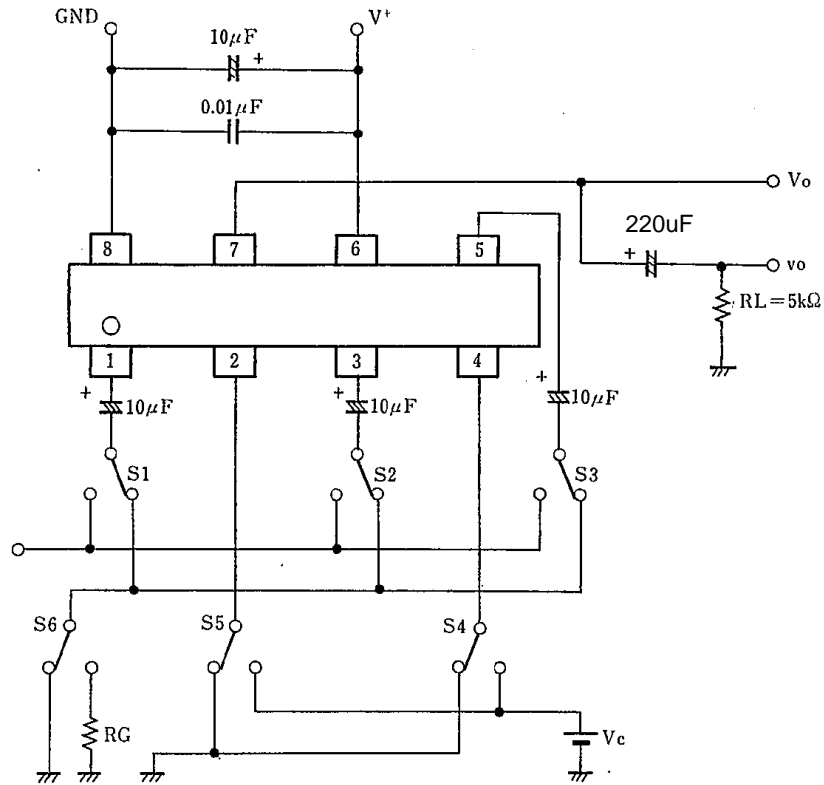

This IC requires $1M\Omega$ resistance between INPUT and GND pin for clamp type input since the minute current causes an unstable pin voltage.



NJM2535

■APPLICATION

This IC requires $1\text{M}\Omega$ resistance between INPUT and GND pin for clamp type input since the minute current causes an unstable pin voltage.

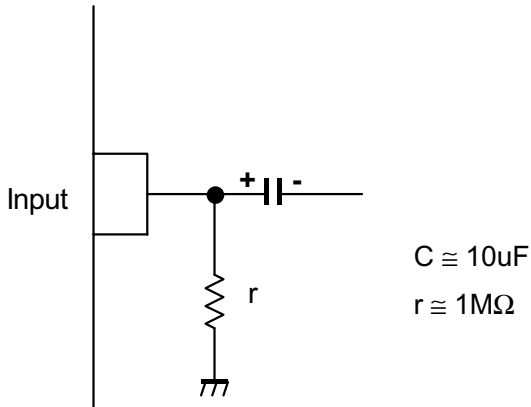

This IC requires $0.1\mu\text{F}$ capacitor between INPUT and GND, $1\text{M}\Omega$ resistance between INPUT and GND for clamp type input at mute mode.

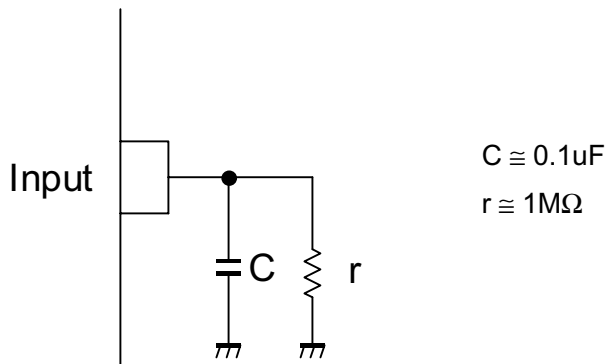

■ TYPICAL CHARACTERISTICS

Supply Current vs. Operating Voltage

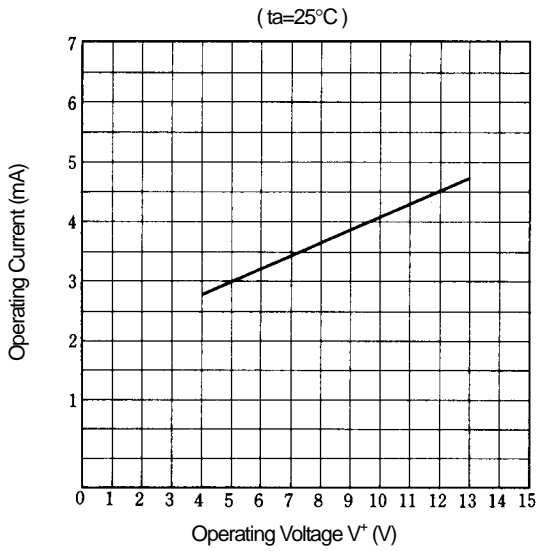

Supply Current vs. Temperature

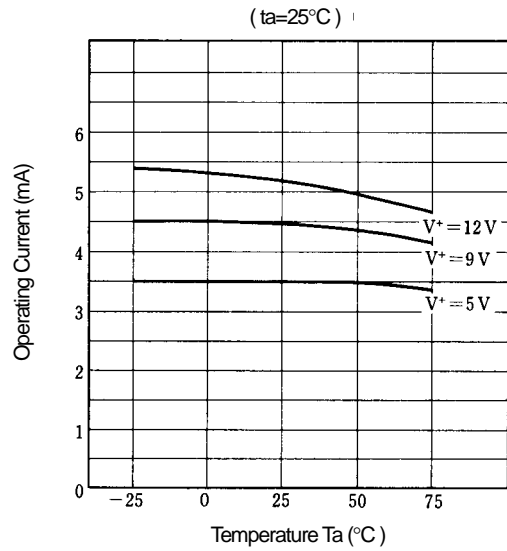

Input DC level vs. Temperature

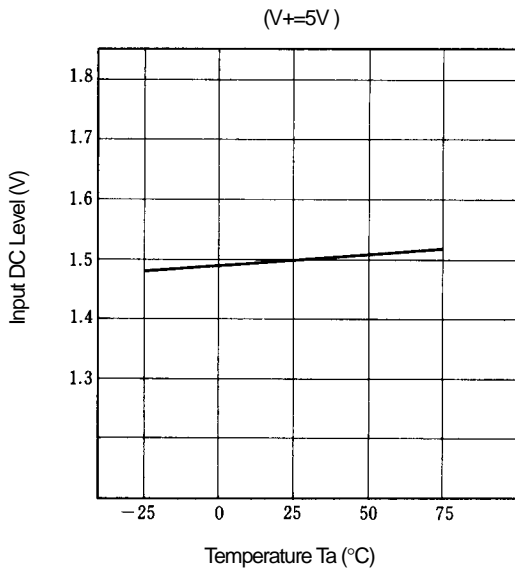

Output DC level vs. Temperature

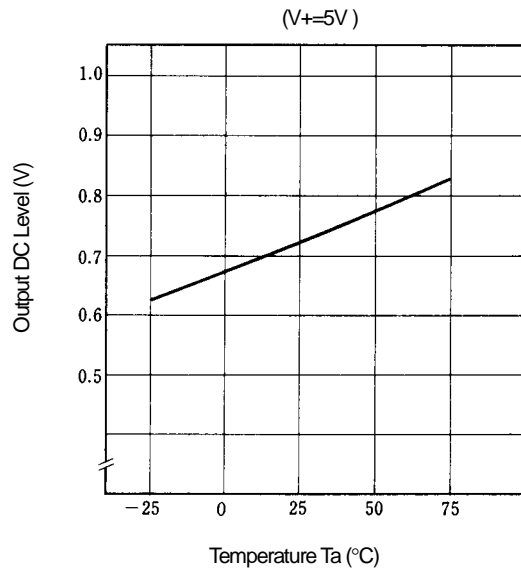

Voltage Gain vs. Frequency

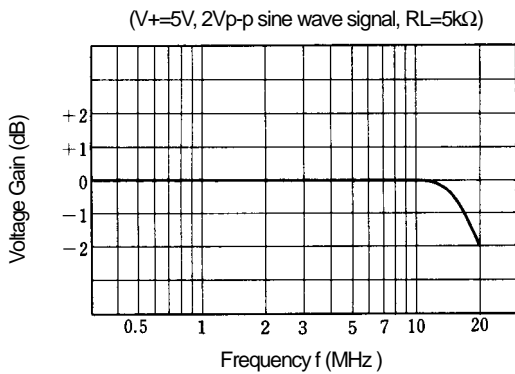

Voltage Gain vs. R_L

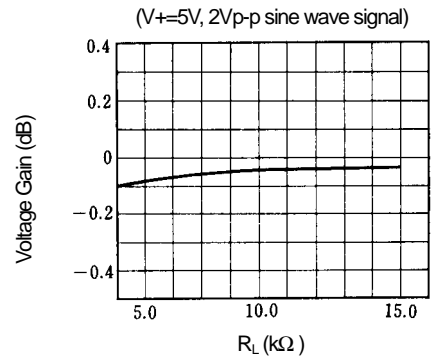

■ TYPICAL CHARACTERISTICS

Differential Gain vs. R_L

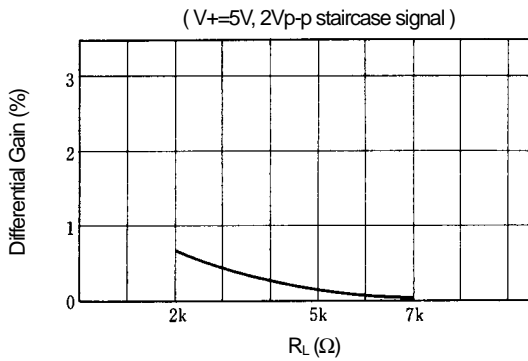

Differential Phase vs. R_L

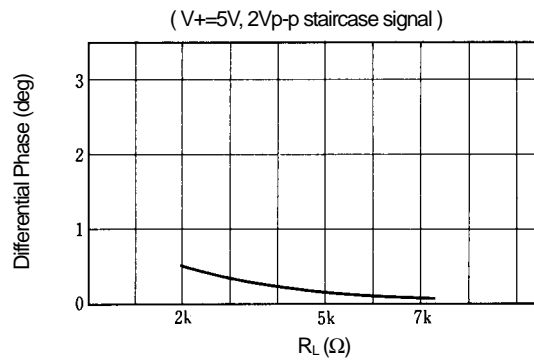

Differential Gain vs. APL

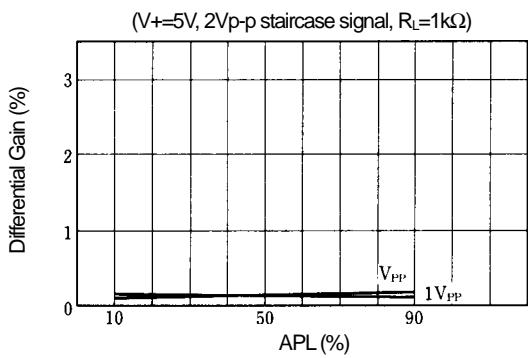

Differential Phase vs. APL

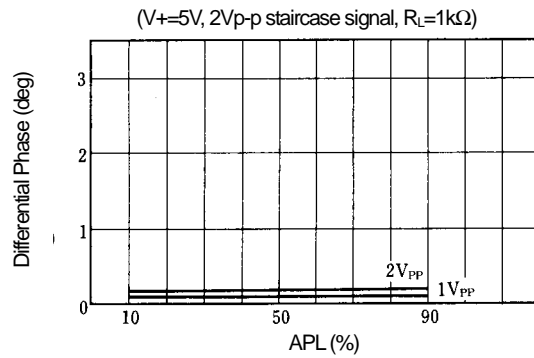

Differential Gain vs. Operating Voltage

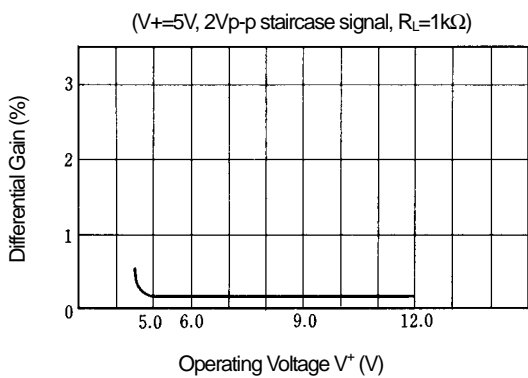

Differential Phase vs. Operating Voltage

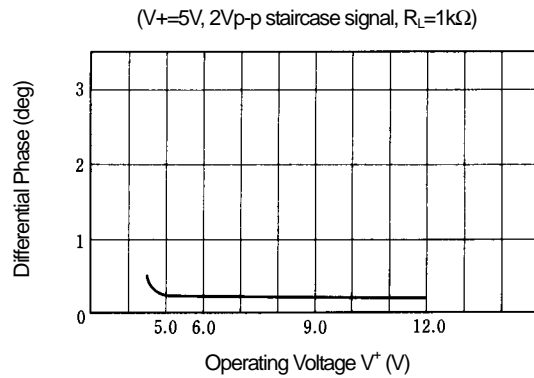

■ TYPICAL CHARACTERISTICS

Differential Gain vs. Temperature

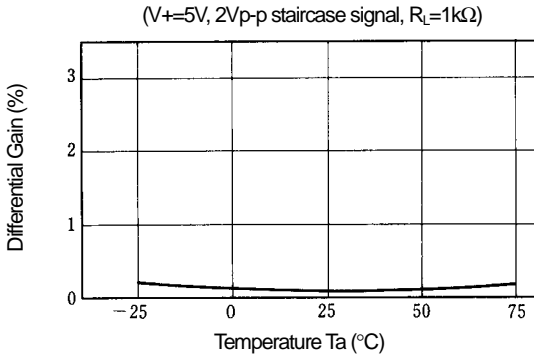

Differential Phase vs. Temperature

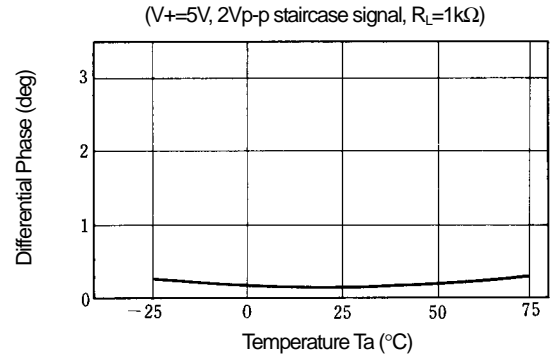

Switching Voltage vs. Temperature

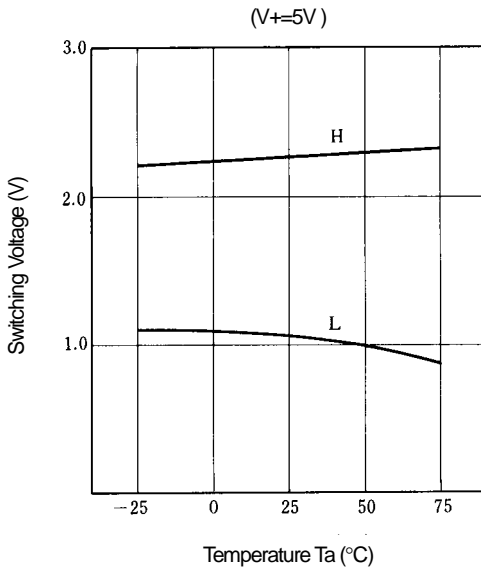

Cross talk vs. R_G

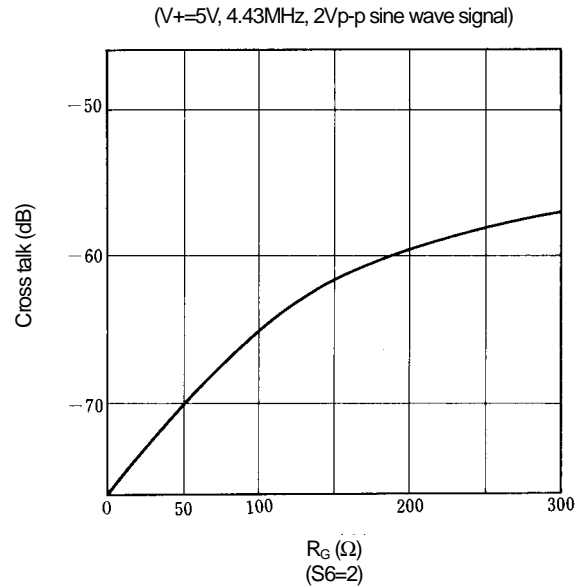

[CAUTION]

The specifications on this databook are only given for information, without any guarantee as regards either mistakes or omissions. The application circuits in this databook are described only to show representative usages of the product and not intended for the guarantee or permission of any right including the industrial rights.